

# INSTALLATION INSTRUCTIONS

## 7/8" FEEDER CABLE



**APPLIES TO  
MODEL NUMBERS**

**78-43M  
78DF  
78-DM  
78-NF  
78-NM**

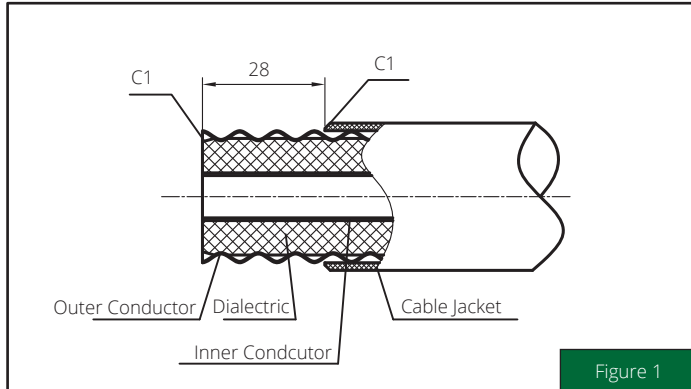

Figure 1

See adjacent diagram (Figure 1) for stripping dimensions. Pay careful attention while stripping.

1. The stripping end of the outer conductor should be at the wave Peak.
2. The end face of the dielectric and the jacket should be chamfered to C1.
3. Remove burrs inside the lip part of the inner conductor.
4. Remove copper scales and burrs of the cable.

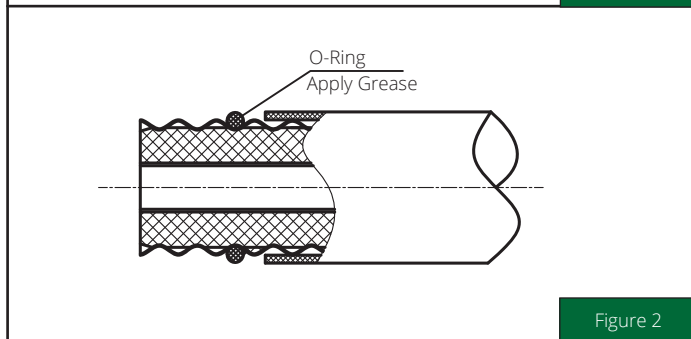

Figure 2

Place the O-Ring onto the trough of the cable after applying grease as shown by adjacent diagram (Figure 2).

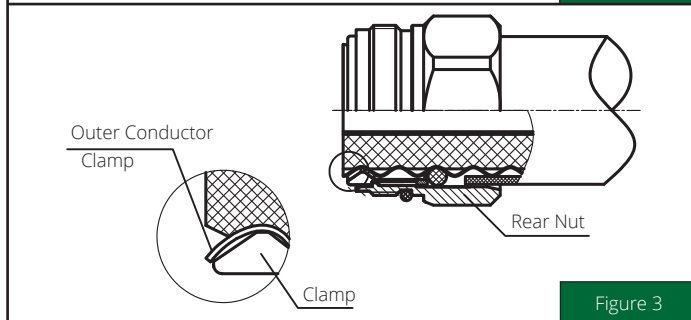

Figure 3

1. Fix the rear nut on the cable so as to be sure that the clamp is in place as shown by adjacent diagram (Figure 3).
2. Then flanging on the cable outer conductor will be carried out to the clamp shown in adjacent diagram (Figure 3).

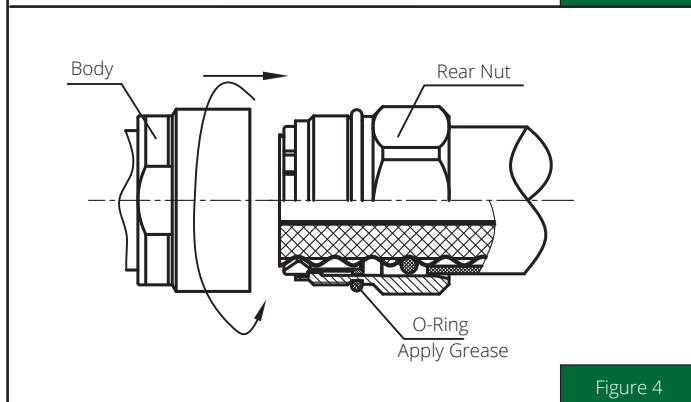

Figure 4

1. Screw the body and rear nut together as shown by the adjacent diagram (Figure 4).
2. Greasing the O-Ring first, screw and tighten the body and rear nut together.